

# ELEIKO SVR PLATFORM - LARGE

Art.no 3085134

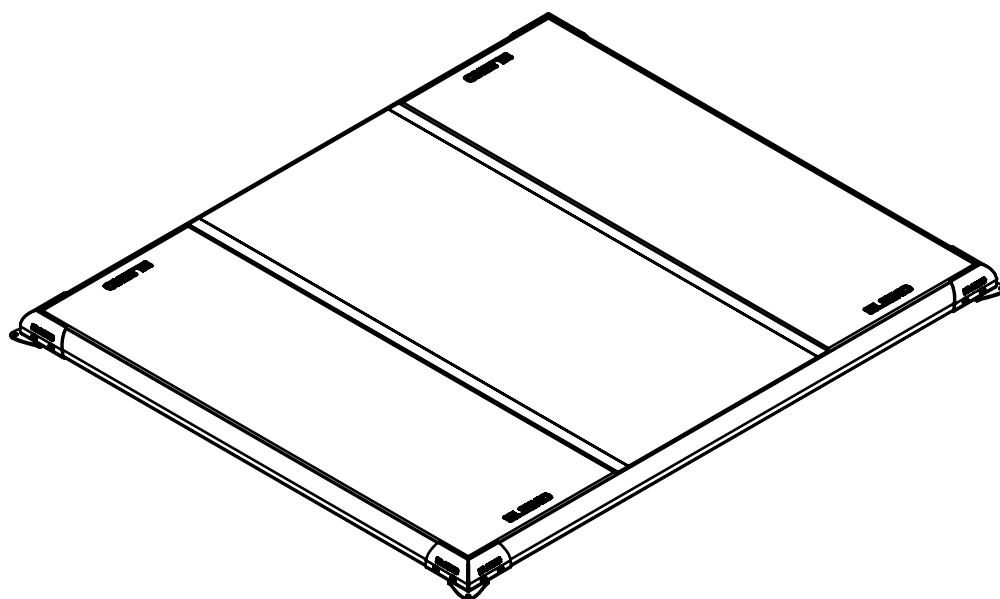

**ELEIKO**

# READ BEFORE INSTALLATION AND USE

## CAUTION

The equipment must be installed and used in a place whose access and supervision are specifically controlled by the owner.

Be sure to install the equipment on a stable base and properly level the equipment. ELEIKO recommends that all equipment is secured to floor and installed by a licensed contractor or an ELEIKO-installer.

## SAFETY INSTRUCTIONS

It is the responsibility of the purchaser of ELEIKO products to instruct all users and supervising personnel on proper usage of the equipment.

1. All included warnings (labels) and instructions **MUST** be read before the use of any ELEIKO-equipment. Use each equipment as it is intended for.
2. A user **MUST** get a medical examination and proper instructions before the use of any ELEIKO-equipment.
3. **DO NOT** let anyone, under any circumstances, use equipment that appears to be damaged. Do not try to repair any equipment before consulting an ELEIKO technician.
4. **DO NOT** replace the components of ELEIKO-equipment with other none ELEIKO-equipment (magnetic safety pin, frames, bars), do not improvise. If there are any doubts consult an ELEIKO representative prior to any intervention.
5. **DO NOT** overload the equipment and **DO NOT** try to exceed personal strength levels.
6. Children under the age of 14 must be supervised by an adult.
7. **DO NOT** remove any safety labels from the ELEIKO-equipment. ELEIKO is not responsible if a label is removed. Replace damaged labels immediately.

## PREVENTITIVE MAINTENANCE & INSPECTIONS

REGULARLY:

Clean the surfaces on frames and tubes from dust and dirt. Vacuum clean rubber tiles.

Check that all bolts between parts, floors are properly tightened, according to recommendations.

EVERY MONTH:

Rotate the Bonded Foam and ARP 220 according to Maintenance Instructions on later pages.

WOODEN DECK:

Clean with wooden floor soap, together with small amount of water. Wooden floor soap can be bought in most floor shops. The wooden deck can be grinded 2-3 times. Contact professionals for advise. Finish with a water-based varnish to protect the deck.



## WARRANTY

All products manufactured by ELEIKO are warranted to the original purchaser to be free from defects in workmanship and / or materials under normal use or service as follows:

Tubings and corners: 3 years

Foam, wooden deck, rubber tiles: 1 year

Normal wear and tear does not fall under the warranty.

## ADDITIONAL INFORMATION

This equipment is for indoor use only.

Designed for weightlifting with rubber discs.

Discs to be dropped on drop zones only.

# ELEIKO

# PRODUCT SPECIFICATIONS

Weightlifting training platform. For indoor use only.

Product weight	260 kg
Dimensions (L x W x H)	2090x2465x105 mm 82.3x97.0x4.1 in

## FOOTPRINT AREA

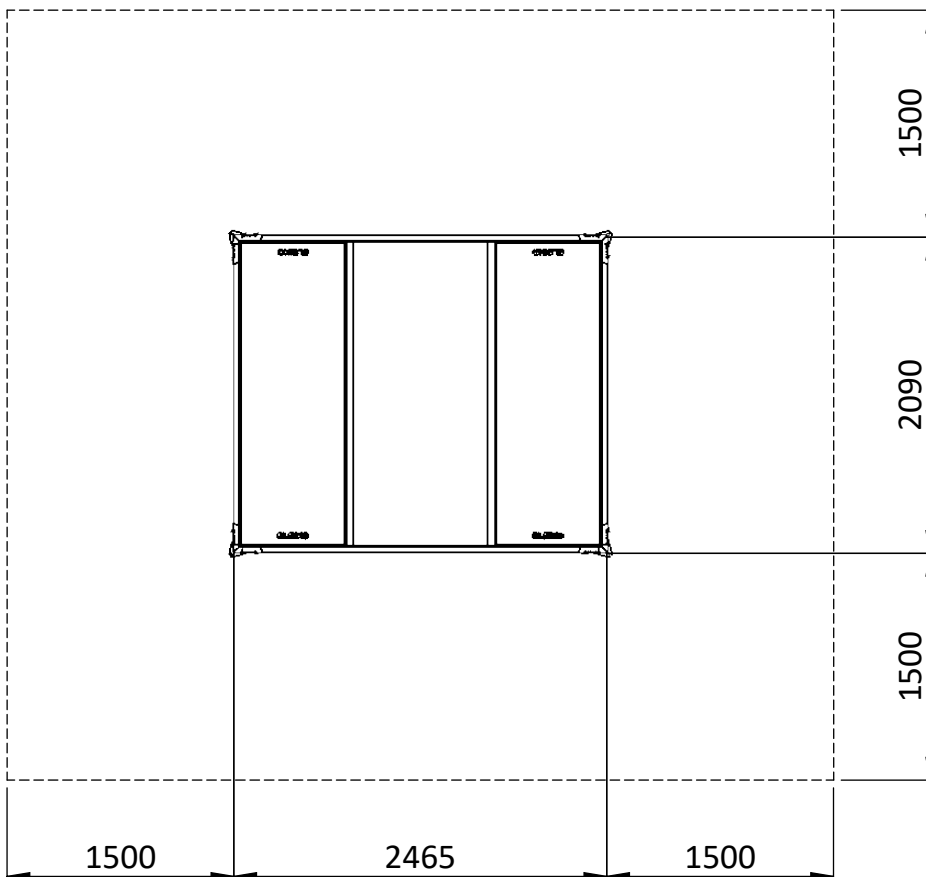

Add sufficient clearance, not less than 1,5 m, on all sides.

# CONTENTS

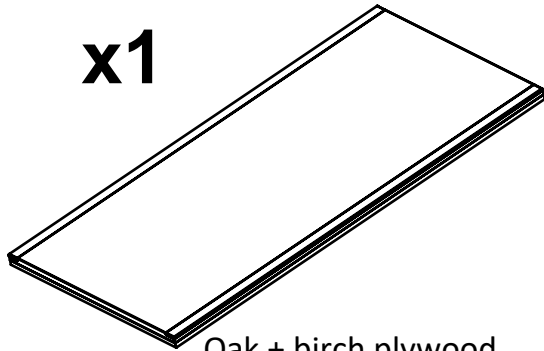

**x1**

Oak + birch plywood  
2010x985x52  
Art No 3060985

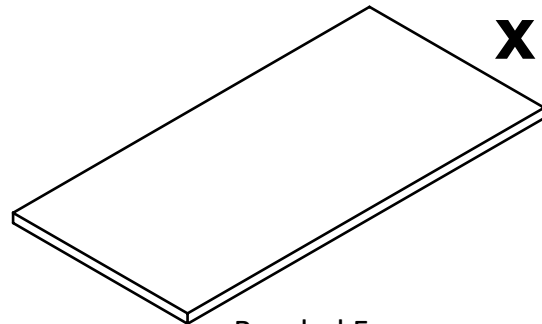

**x1**

Bonded Foam -  
2000x980x50 mm  
Art No 2000614

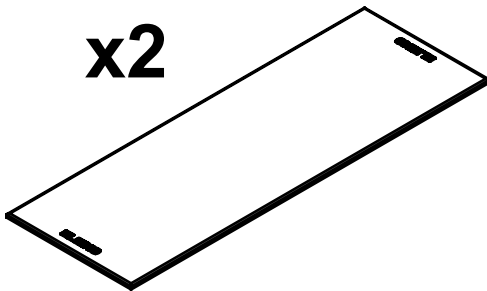

**x2**

Rubber Tile 2010x700x20  
Art No 2000802

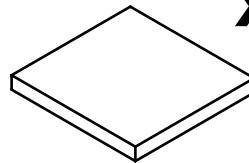

**x6**

Bonded Foam -  
666x695x70 mm  
Art No 2000820

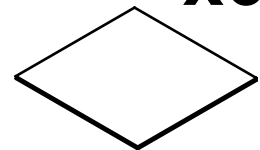

**x6**

ARP 220 black,  
666x685x12.7 mm  
Art No 2001901

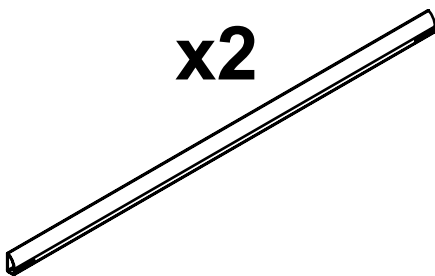

**x2**

Tube 40x90x3, L=2360  
Art No 2000487 p2

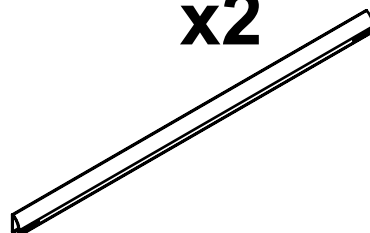

**x2**

Tube 40x90x3, L=1985  
Art No 2000487 p1

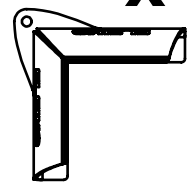

**x4**

Corner for SVR Platform  
Art No 3085208



**x16**

Screw M10x25  
Art No 2001124-L25



**x8**

Flat iron 20x6 L=120  
Art No 2000520 p5

## REQUIRED TOOLS

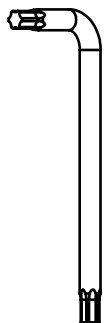

Torx wrench  
TX 50

## GENERAL

The table below is general torque to use for different threads. Use these torques, if nothing else is set. Below numbers are for screw/nut of quality 8.8.

THREAD	TORQUE (Nm / ftlb) Quality 8.8
M10	47 / 34,7

# ASSEMBLY INSTRUCTIONS

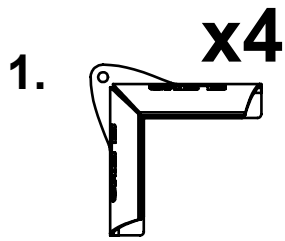

Corner for SVR Platform  
Art No 3085208

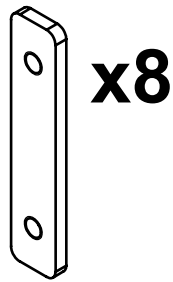

Flat iron 20x6 L=120  
Art No 2000520 p5

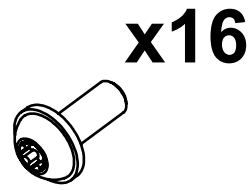

Screw M10x25  
Art No 2001124-L25

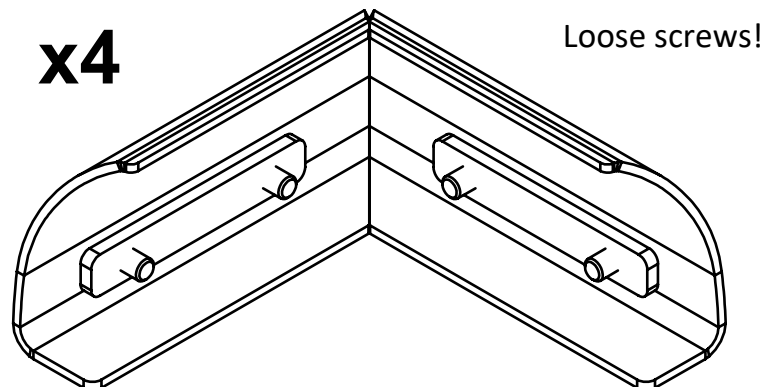
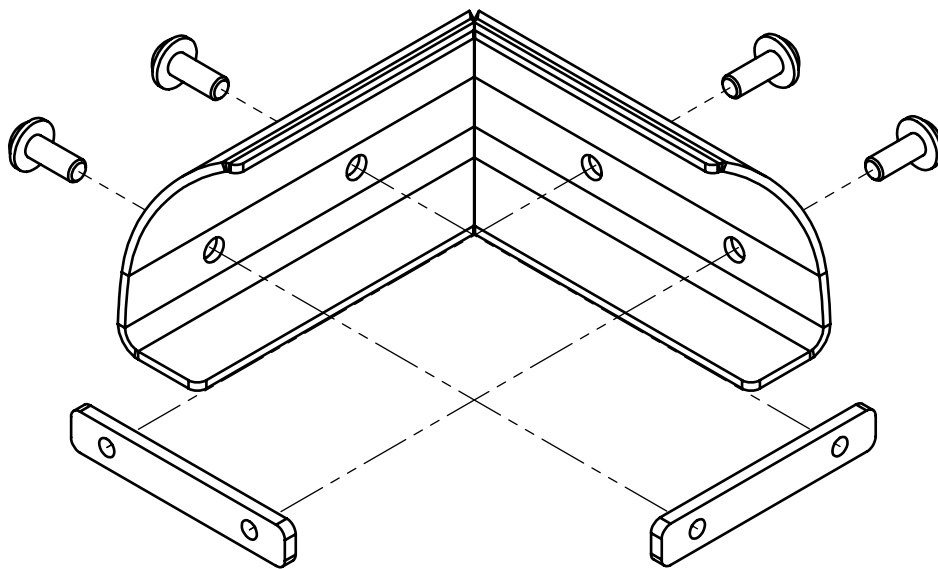

2.

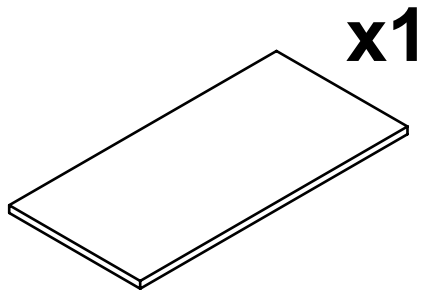

Bonded Foam -  
2000x980x50 mm  
Art No 2000614

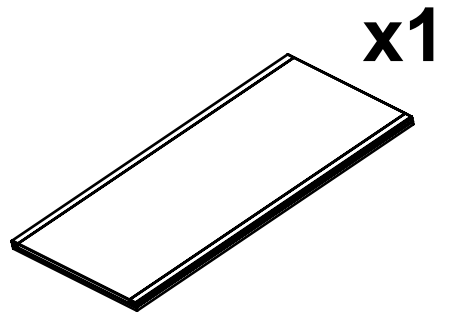

Oak + birch plywood  
2010x985x52  
Art No 3060985

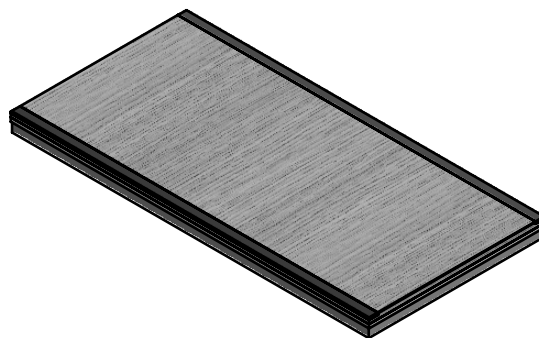
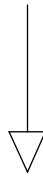
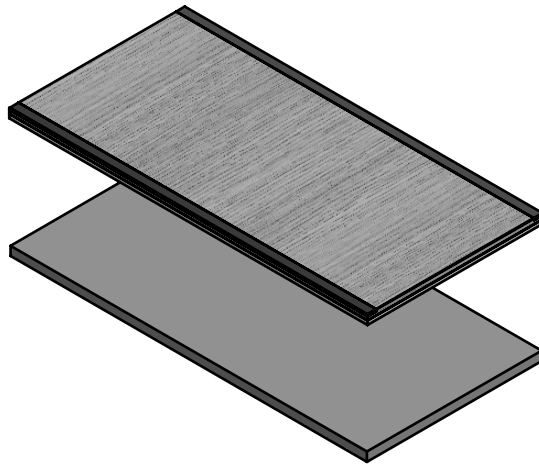

3.

x6

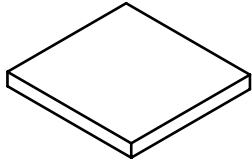

Bonded Foam -  
666x695x70 mm  
Art No 2000820

x6

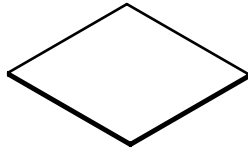

ARP 220 black,  
666x685x12.7 mm  
Art No 2001901

x2

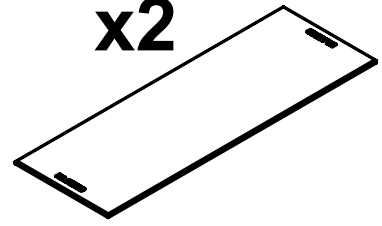

Rubber Tile  
2010x700x20  
Art No 2000802

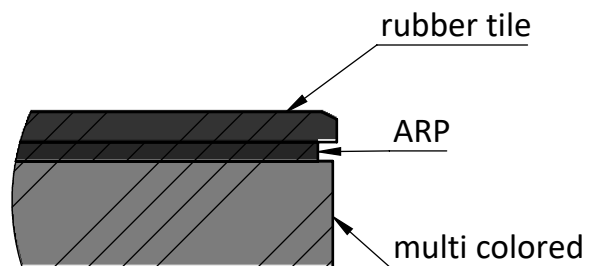
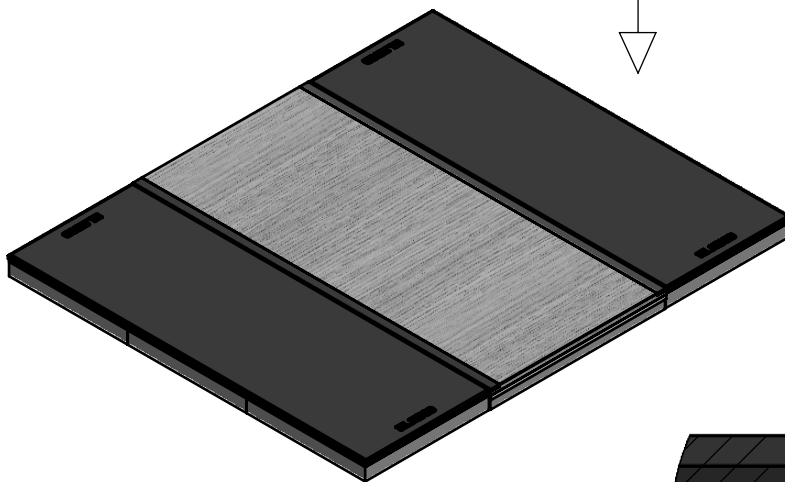
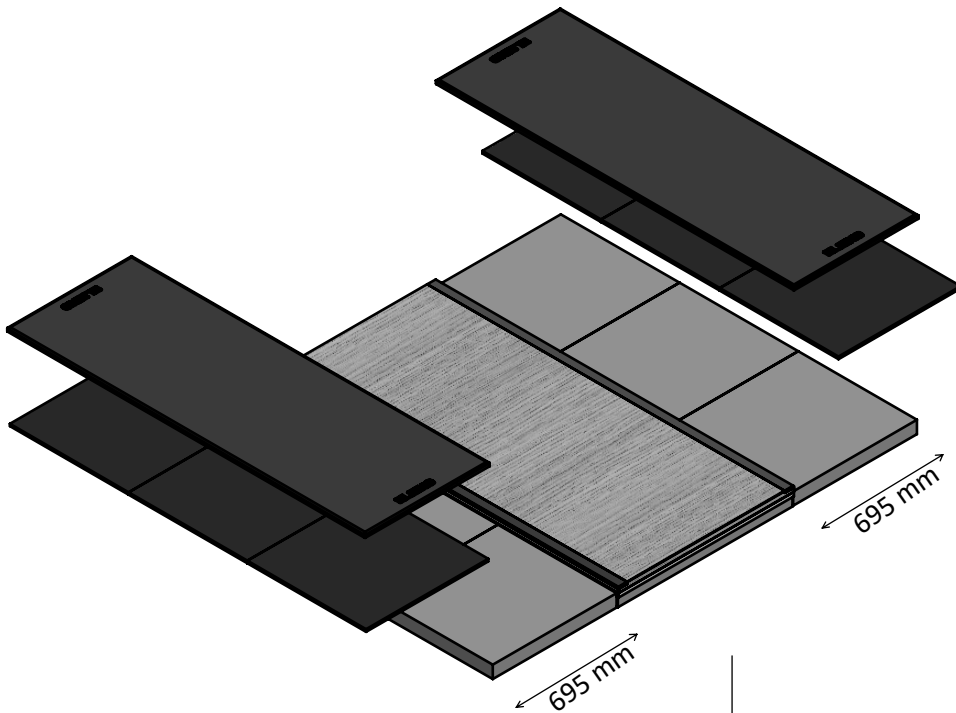

Make sure to assemble the tiles in right order.



4.

x2

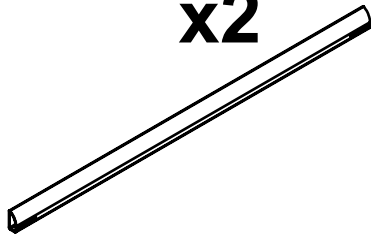

Tube 40x90x3,  
L=1985  
Art No 2000487 p1

x2

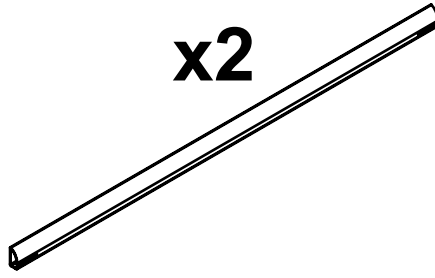

Tube 40x90x3,  
L=2360  
Art No 2000487 p2

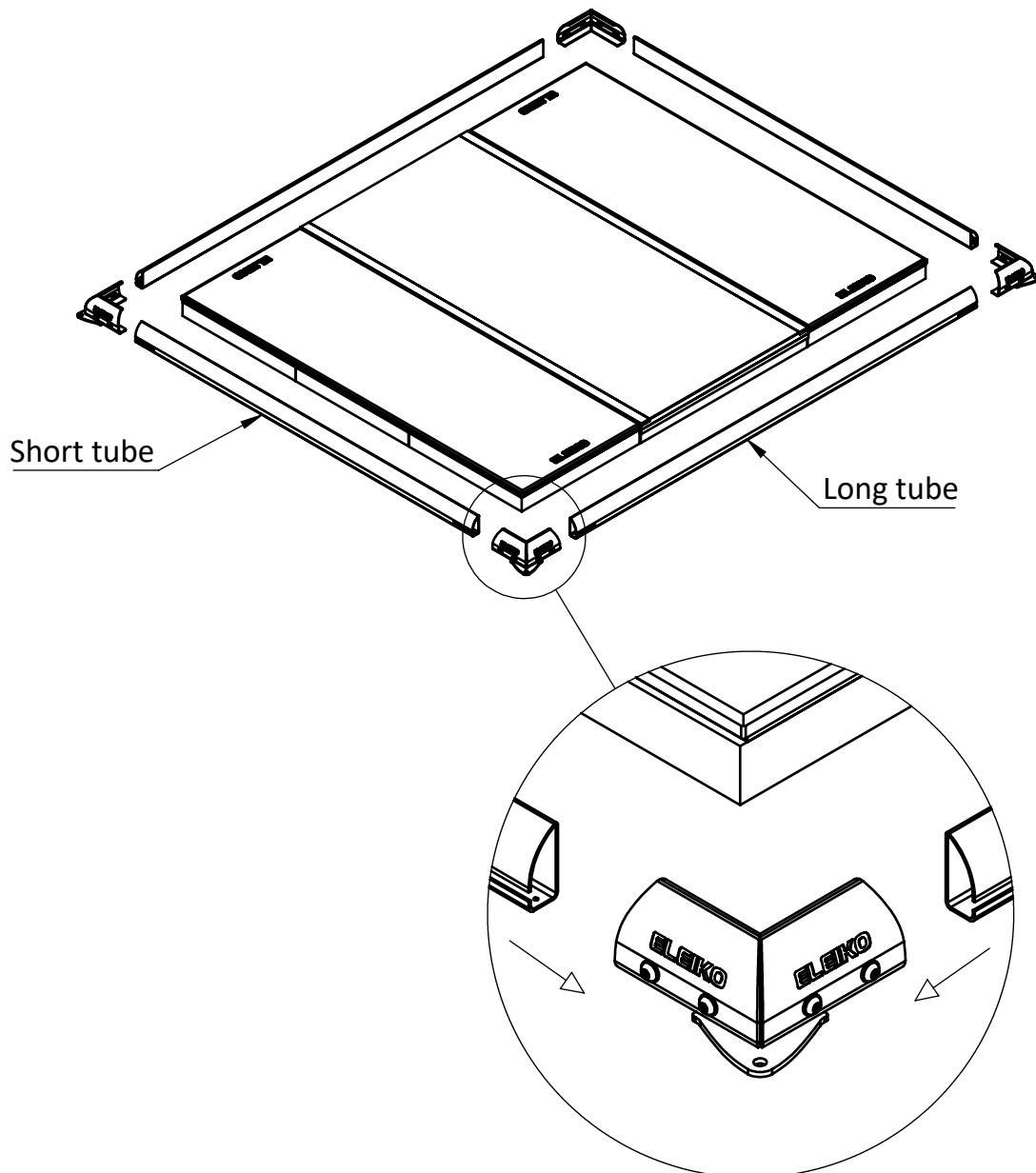

**ELEIKO**

**5.**

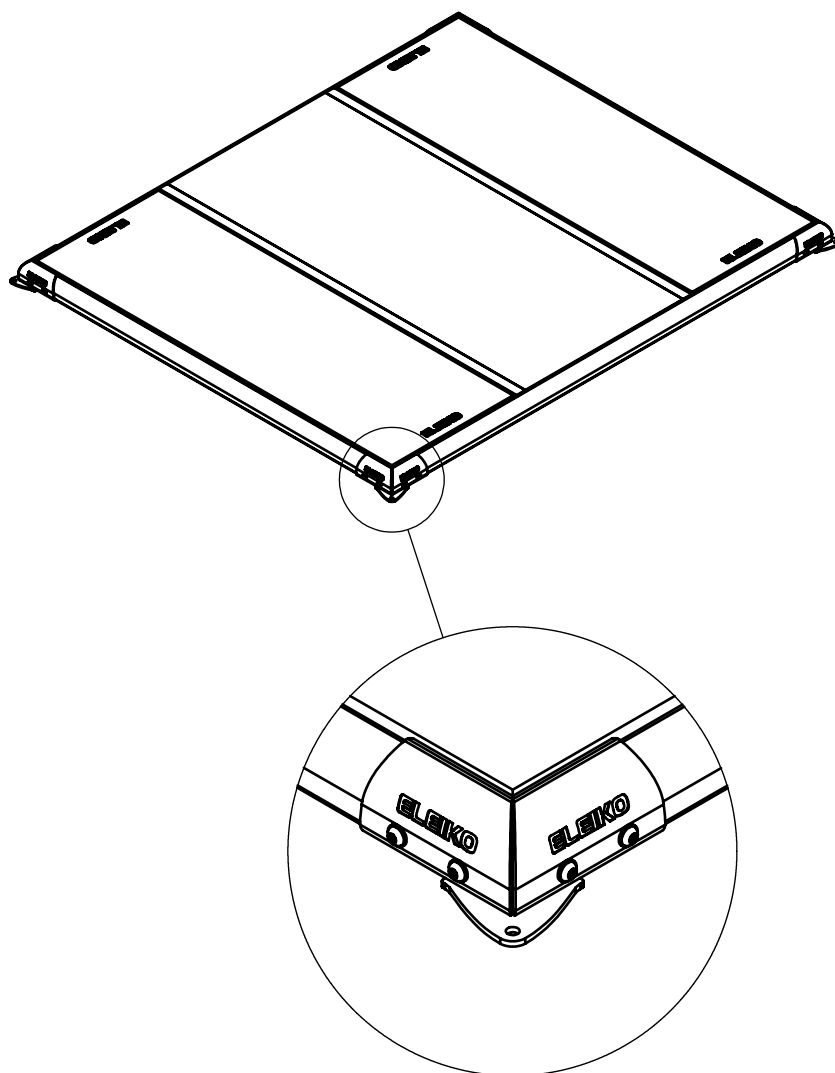

**Tighten frame and screws just to hold them in place.  
Make your way around and tighten the screws hard in  
a criss cross pattern.**

**ELEIKO**

# MAINTANANCE INSTRUCTIONS

1.

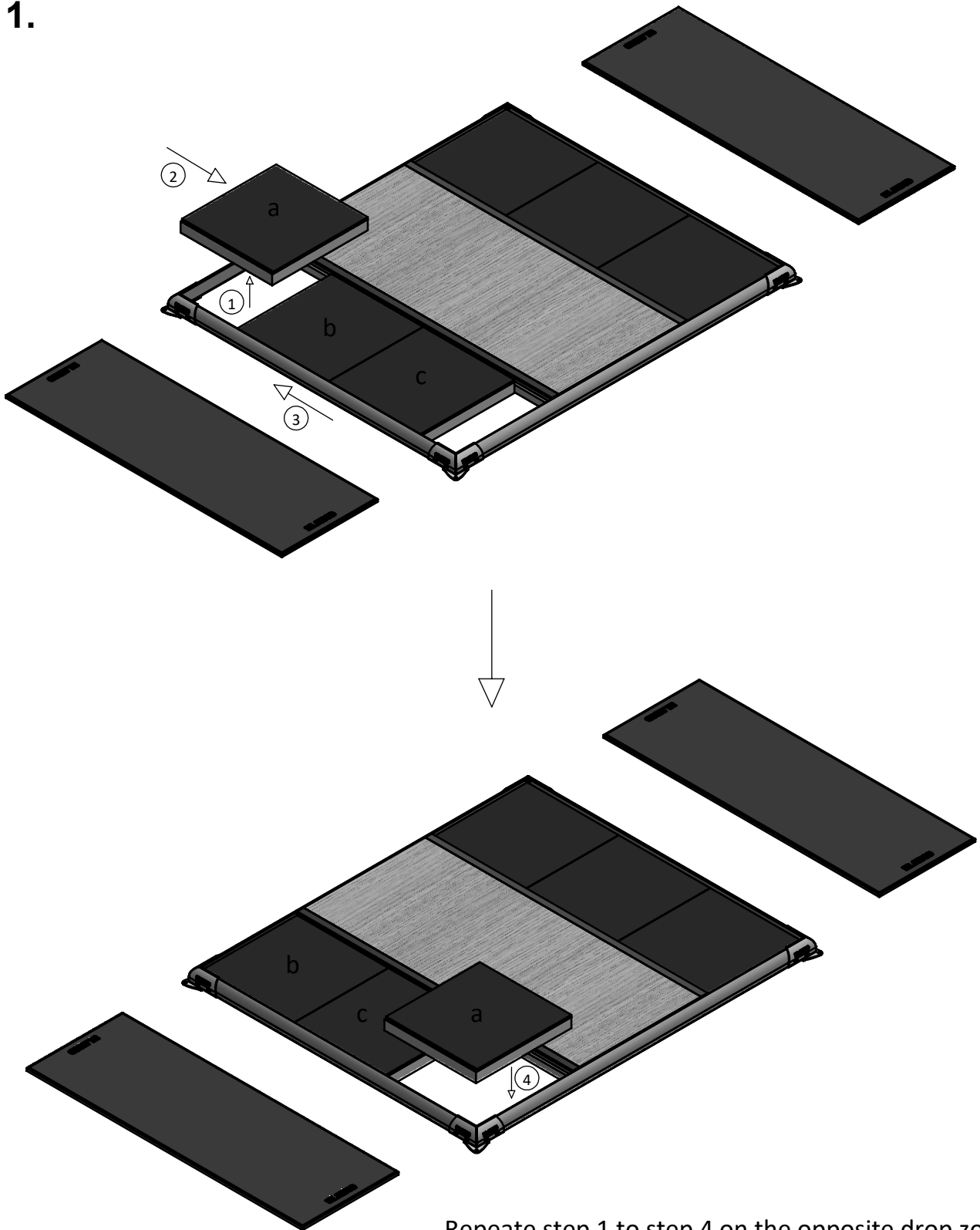

Repeate step 1 to step 4 on the opposite drop zone.  
Put back the rubber tile on top.

# ELEIKO

RAISE THE BAR

Eleiko Group AB | Klastorpsvägen 18 | SE-302 62 HALMSTAD | Sweden  
E-mail: [info@eleiko.com](mailto:info@eleiko.com) | Phone: +46 35 17 70 70

[www.eleiko.com](http://www.eleiko.com)