

Perfect® AB-CRUNCH

User Guide



©2017 Implus LLC • All rights reserved
Perfect Fitness® and Perfect® are registered trademarks of Implus LLC.
U.S. and International Patents Pending.
www.PerfectOnline.com

NO part of this booklet may be reproduced or utilized in any form or by any means electronic, mechanical or otherwise without the expressed written consent of the copyright holder.

Introduction

Getting in shape takes a positive attitude and determination. The right equipment makes achieving your fitness goals easier, so congratulations on your purchase of the Perfect Ab-Crunch. The Perfect Ab-Crunch is key to an effective, time-efficient exercise regimen. No matter your fitness level, you can progress at a rate that's right for you using Perfect Fitness products.

Sticking with a program of regular exercise takes persistence. We encourage you to go to www.PerfectOnline.com to find out about new products, get workout tips and view workout videos.

Like us on Facebook at www.facebook.com/perfectfitness - it's a great place to share your progress. Follow us on Instagram [Perfect_Fitness_](https://www.instagram.com/Perfect_Fitness_). Many of our top users have created their own exercise routines using our products and use hashtag **#PerfectFitness**.

IMPORTANT:

This User Guide is the authoritative source of information about your Perfect Ab-Crunch. Please read it carefully and follow all the instructions.

Comments or Questions?

If you have any comments or questions about your Perfect. product, **INSTRUCTIONS** or **WARNINGS**, please email, call or write to our Customer Service Specialists. Our goal is your complete satisfaction.

Perfect, Customer Service Department 2001 T.W. Alexander Drive,
Box 13925, Durham, North Carolina 27709-3925

Call Toll Free: 1-877-974-7733, Monday through Friday, 8:00 am to 5:00 pm, EST
Email: help@4implus.com

www.PerfectOnline.com

Important Safety Information

⚠ WARNING

FAILURE TO READ AND FOLLOW THE SAFETY INSTRUCTIONS STATED IN THIS USER GUIDE MAY RESULT IN POSSIBLE SERIOUS INJURY OR DEATH.



1) **BEFORE EACH use, visually inspect the equipment. NEVER use this equipment if it is not working properly or if there are damaged or worn parts.** Call our Customer Service Department with any questions.

2) **CONSULT your physician before starting this or any other exercise program.**

Fitness training can result in **SERIOUS INJURY OR DEATH**. Risk of injury can be lessened when safe techniques and common sense are practiced. **Before beginning your first workout, become familiar with the Perfect Ab-Crunch and review all exercise guidelines prior to using the equipment.** Your physician should assist you in determining the target heart rate zone appropriate for your age and physical condition. Certain exercise programs or types of equipment may not be appropriate for all people. This is especially important for people over the age of 35, pregnant women, or those with preexisting health problems or wrist, elbow, shoulder or other joint and/or muscle impairments. **If you are taking medication that may affect your heart rate, a physician's advice is essential before use of this equipment.**

3) **DO NOT** use if you are over 300 lbs/136 kg

4) **USE on a non-skid surface ONLY. DO NOT use on surfaces such as tile, linoleum or on surfaces that are wet such as a pool deck. DO NOT sit on product.**

5) **DO NOT overexert yourself with this or any other exercise program.** Listen to your body and respond to any reactions you may be having. You must learn to distinguish "good" pain, like fatigue, from "bad" pain, which hurts. **IF** you experience any pain or tightness in your chest, an irregular heartbeat, dizziness, nausea or shortness of breath, **STOP** exercising at once and consult your physician immediately.

6) **IT IS strongly suggested that handicapped or disabled people have medical approval** before using this equipment and should be under close supervision when using any exercise equipment.

7) **WARM UP** before any exercise program by doing 5 to 10 minutes of gentle aerobic exercise, such as walking, followed by stretching.

8) **START OUT slowly and progress sensibly.** Even if you are an experienced exerciser, start with the easier modifications of the exercises and become familiar with all of the exercises before moving on to more advanced modifications.

9) **BREATHE naturally**, never holding your breath during an exercise. Avoid over training, you should be able to carry on a conversation while exercising.

10) **USE this equipment ONLY for the intended use as described by the manufacturer. DO NOT modify the equipment or use attachments not recommended by the manufacturer.**

11) **HAVE plenty of clearance space.** It is important to keep children, pets, furniture and other objects out of the way when using your equipment. You should have a minimum of 3 feet of clearance space to avoid unnecessary physical contact.

12) **WEAR appropriate clothing when exercising.** Clothing should be comfortable and lightweight, and should allow freedom of movement. Wear comfortable athletic shoes made of good support with non-slip soles, such as running or aerobic shoes.

Specifications & Parts

Approximate:

Length:27"

Depth:24.2"

Hight:26"

Product Weight:5.5 lbs / 2.5 kg

Maximum User Weight:300 lbs/136 kg

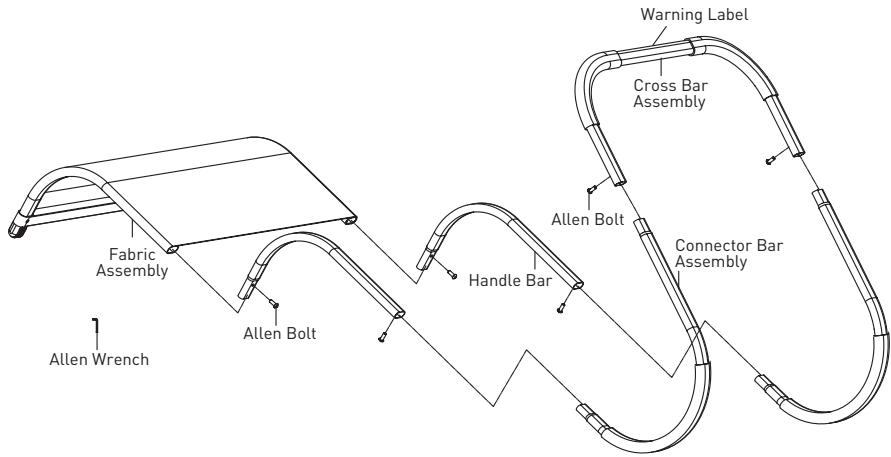

Assembly

Step 1

Insert Handle Bar into Fabric Assembly, and screw the Allen Bolt with Allen Wrench securely.

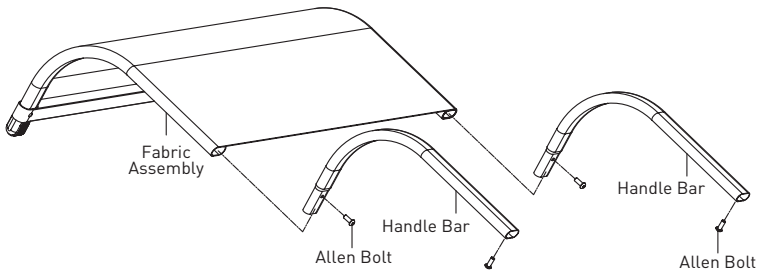

Step 2

Insert Fabric Assembly into Handle Bar Assembly, and screw the Allen Bolt with Allen Wrench securely.

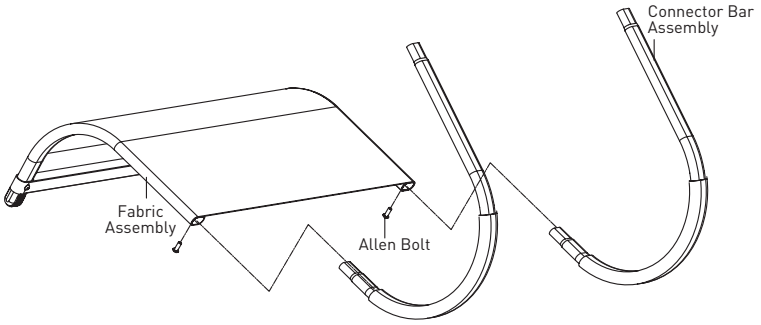

Step 3

Insert Connector Bar Assembly into Handle Bar Assembly, and screw the Allen Bolt with Allen Wrench securely.

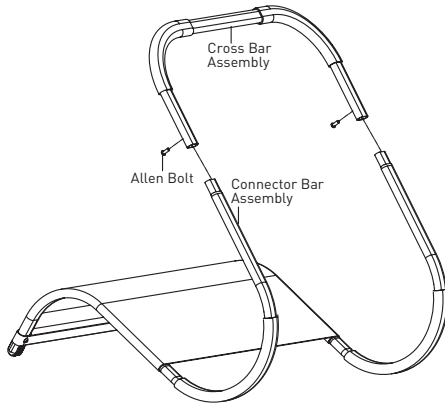

Step 4

Installation finished.

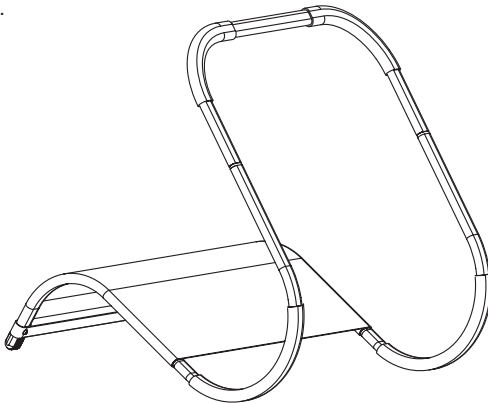

Equipment Warning Label

IMPORTANT: See image for placement of this Warning Label on your equipment.

⚠ WARNING

Failure to read and follow the safety instructions stated in the Owner's Manual may result in **SERIOUS INJURY OR DEATH. KEEP CHILDREN AWAY. DO NOT** use if you weigh more than 300 lbs/136 kg. Use on **NON-SKID** surface only. **DO NOT** sit on product. Only perform exercises recommended by the manufacturer. Class HC. Go to our website: www.PerfectOnline.com or call Customer Service: 1 877 974 7733 for replacement label, manual, or questions.

Warning

Before each use, visually inspect the device. Never use the device if it is not working properly.

Care and Storage

THE Perfect Ab-Crunch has been carefully designed to require minimum maintenance. Before each use, visually inspect the device. Never use the device if it is not working properly.

CARE Instructions: Remove the Handles and wipe down with a clean damp cloth.

STORAGE: Store your unit out of the reach of children.

DO NOT store in direct sunlight or near direct heat sources.

Workouts

Go to www.perfectonline.com/workouts to download free workout guides. The downloadable content concentrates on four key aspects of fitness: Core, Push, Pull and Strength. When combined, the Perfect® products and programs create the perfect full body workout solution.

Perfect®

Perfect develops innovative fitness solutions that maximize muscle engagement and biomechanical efficiency. Our products use simple, natural movements and back-to-basics principles to enable anyone to unlock their potential. Visit www.PerfectOnline.com to learn more.